

Application, Installation & Maintenance Manual

“Your Problem Water Specialist”

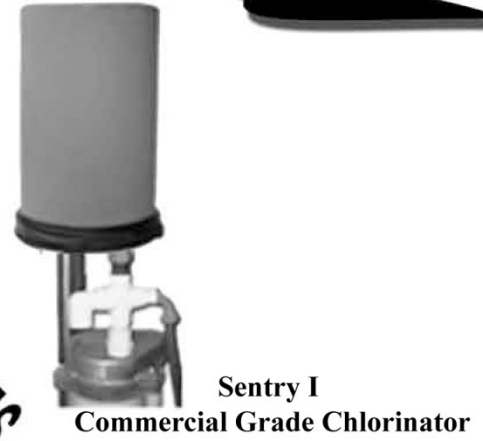
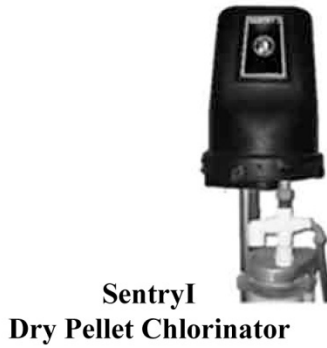

Providing Exceptional Service Since 1986

This is professional grade equipment designed to be installed and serviced by trained water conditioning professionals.

Better Water Industries, Inc.

Better Water Industries Inc. (BWI) established a culture in 1986. That culture has remained a mainstay of the company, from the early stages, through the company's growth, and in our vision of the future. BWI takes a strong interest in our clients by providing not only exceptional equipment, but also the knowledge and tools for their companies to succeed. We pride ourselves on loyalty and customer service, along with having a strong and incomparable network of contacts that can assist in any application within the water conditioning business. The culture is simple: we are small enough to care, but large enough to provide exceptional service. BWI has set itself apart in the industry, as we are capable of complimenting a large number and variety of clients and the equipment they sell, while still maintaining a personal touch. We believe in the old adage that our handshake and our word are firm, and we believe that is something that, unfortunately, has been lost in today's business environment. We thank our existing clientele, and look forward to new business opportunities as well. Please contact Better Water Industries, Inc. for more information, and begin to experience what a business culture and experience should be.

209 North Tyler St.

Tyler, MN 56178

Phone: 507-247-5929

Fax: 507-247-3416

E-mail: bwi@betterwaterind.com

Web: www.betterwaterind.com

Table of Contents

<u>Sentry I Dry Pellet Chlorinator</u>	Page#
Installation & Preparation	PG-4
Preparing the Well	PG-4
Wire & Vent Kit	PG-5
Standard Wire & Vent Kit	PG-5
Vermin – Proof Wire & Vent Kit	PG-5
Attaching the Bracket	PG-6
Lining up the Drop Tube	PG-6
Wiring of your Sentry I	PG-6
Important Wiring Schematic	PG-7
Setting the Chlorinator	PG-8
Chlorine Demand Calculations.....	PG-8
Determining Pump Production.....	PG-8
Chlorinator Pellet Gear Settings.....	PG-9
Table 1: Ten Tooth Gear Set	PG-9
Table 2: Pellet Gear Setting.....	PG-9
Finishing Touches.....	PG-10
Enlarged Parts List.....	PG-10
Maintenance & Repair of the Chlorinator	PG-11
Removing a motor gear	PG-11
Changing the motor on a Chlorinator.....	PG-11
Tips for installing and service	PG-11
Preventive Maintenance	PG-11
Recirculation Check Valve & Basket Installation	PG-12
Commercial Chlorinator Specifications	PG-12
Commercial Chlorinator.....	PG-13
Water Volume & Contact Time.....	PG-14
Sentry I Pellet Chlorinator on a Storage Tank.....	PG-15
Suggested Filtration.....	PG-16
Multi-Media Carbon Filter	PG-16
Multi-Media Non-Carbon Filter	PG-16
<u>Sentry I Open-Air Systems</u>	
Open-Air Installation.....	PG-17
Open-Air Summary	PG-18
Conventional Layout	PG-18
Open-Air Wiring Diagram.....	PG-19
Open-Air Specifications	PG-20
Scheduled Maintenance.....	PG-20
Open-Air Parts List.....	PG-21
Flow Meter	PG-22
Trouble Tree	PG-23
Test Survey.....	PG-26
System Notes.....	PG-27
Warranty	PG-28

Installation & Preparation for Sentry I Chlorinator

Better Water Industries, Inc., recommends that you have the proper tools handy that are necessary to install the Sentry I. Tools included are:

Flashlight	9/16" Wrench
10' 3/4" CPVC	Hacksaw
1 3/8" Hole Saw	Pliers
5/16" Nut Driver	1/2" Drill
Electrical Tape	Hose Clamp
Mirror	Rubber Hammer
Tape Measure	Screwdriver
Channel Locks	2 Wire Nuts
1/2" Wrench	7/8" Hole Saw
Wire Vent Kit	
(Sold Separately)	



Before installing your Sentry I, BWI, Inc. Recommends that you work closely with your State agency as approval may be necessary.

Preparing the Well

The following should be used when either preparing the well for installation or preparing the well in the event that the SENTRY I hasn't been in use for more than 30 days.

When you remove the sanitary seal well cap use a mirror or flashlight and see what kind of pit less adapter there is in the well. Slide the tapered end of the drop tube past the pit less adapter before dropping any pellets. Be careful so the drop tube doesn't slip or fall down the well. Drop 15-25 chlorine pellets down the 3/4" x 10' CPVC drop tube to help satisfy the initial chlorine demand of the well. When dropping pellets ensure you hear the sounds of "PLUNK" this will ensure that the pellets have a clear passage to the water.

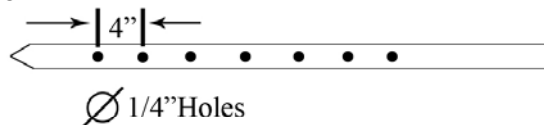

NOTE: Predrilled, tapered-end drop tubes are used to promote moisture release, prevent pellet clogging and help with the installation past the pit less adapter.

Taper the drop tubes by using a hacksaw and cutting one end of the tube in a "V" shape about 1 - 1/2 long. Next, drill 1/4" holes in the bottom 2/3rds of the tube approximately 4" apart making sure there are no plastic shavings on the inside which might stop the pellet from dropping through. Drill all the way through the tubes so each drilling motion creates two holes. Most dealers' inventory pre-drilled and pre-cut tubes to save installation time.

Note: High static water levels (20' or less) require a drop tube without any holes drilled in it. In this application the drop tube should be submerged one (1ft) in the water.

Wire & Vent Kit Installation

Type 1: Standard Wire & Vent Kit Part# M 120005

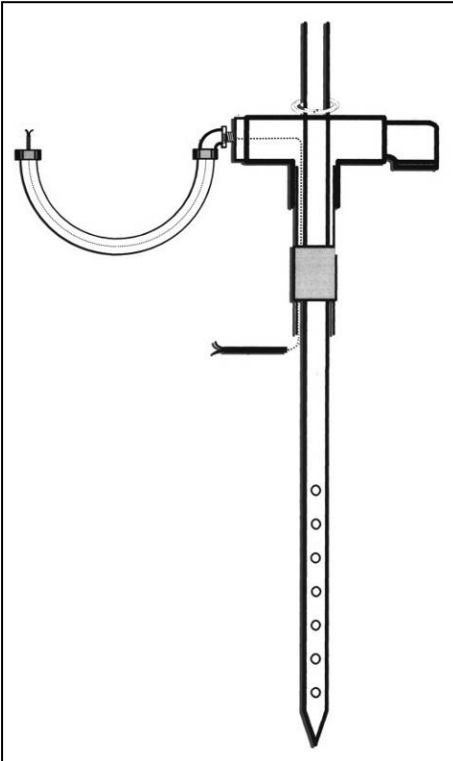

There are two ways to do this. You can either drill three holes (one for the drop tube, one for the electrical connection, and one for the vent) or drill one hole and use BWI's Wire and Vent Kit.

BWI recommends using the Wire and Vent Kit and drilling a single hole. We recommend this because it is important to have adequate venting with each installation. This speeds up the installation time and gives the installation a professional look.

Remove the well cap when drilling and place it on the ground and drill straight down into the cap with a 1-3/8" hole saw. This hole should line up with the hole in the pit-less adapter so that the chlorine tablets will have a straight drop to the water in the well.

Drill straight down, slightly off the middle of the cap. You will get a "feel" as to where to drill the hole as you install more Sentry I's. Make sure that the hole is drilled straight and not at an angle -- as this will help with the alignment of the Wire and Vent Kit and Drop Tube.

For your first few installations, you may want to line up the hole by attaching the bracket before you start to drill. Install the Sentry I from the well casing up to the

Sentry I system. After a few installations you will know by the sight as to where the single hole should be drilled.

Type 2: Vermin – Proof Part# M 120019

When installing the Sentry I with the pre-drilled, vermin-proof, water-tight cap with the 1-1/4" threaded hole, use the Sentry I Wire and Vent Kit.

We recommend this because it is important to have adequate venting with each installation. A minimum additional vent surface area of .75 square inches is provided with the Sentry I Wire and Venting Kit itself. This must be used in the installation.

In all cases the well cap being used must be an approved sanitary seal or an approved vermin-proof, water-tight cap. In many applications this cap is necessary and can be ordered from BWI.

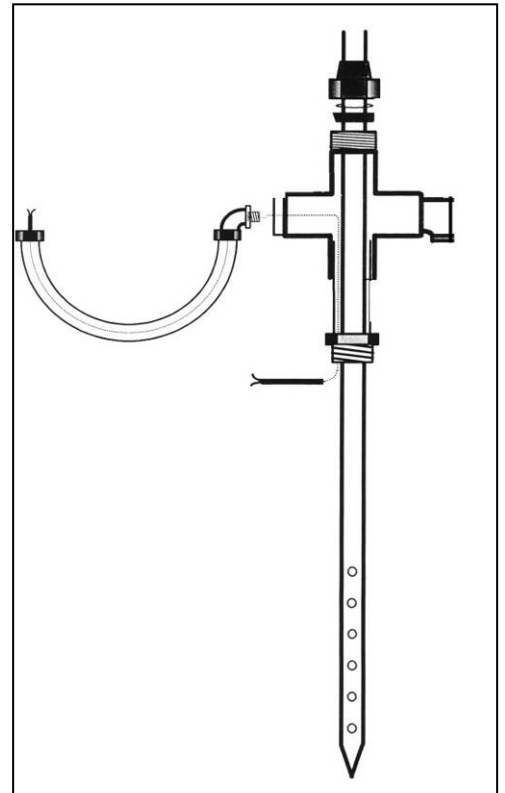

Attaching the Bracket

Place the two casing adapters around the well casing. You will notice that the casing adapters are sized to fit perfectly around a 4" well casing. For larger size casings use your rubber hammer to "shape" the casing adapter to the arc of that particular well casing.

Included with the Sentry I are two 18" pieces of 2000# tensile strength strapping. Measure the strapping between the eyelets of the casing adapter once you have fitted the casing adapter around the well casing. Add 2 inches to the length between the eyelets and cut off the excess strapping. Bend the strapping with pliers one inch from each end of the strapping. Place the strapping in each eyelet with the 1" bend facing the well casing (on the inside) and tighten snug the bolts on the casing adapter.

You will be able to put the standpipe in the casing adapter and be able to "swing" the entire adapter assembly around the well if necessary. (It is important to line up the drop tube straight down through the well casing as it extends from the bottom plate. Final tightening shouldn't be done until the bottom plate is attached).

Lining up the Drop Tube

Place the Sentry I bottom plate on the standpipe and turn the bracket so that the drop tube extends through the hole in the "T" of BWI's Wire and Vent Kit and into the hole on the underside of the bottom plate. It is important to have a straight drop into the well.

Make sure the Sentry I bottom plate is pushed all the way on the standpipe. Once it is on the standpipe, tighten the hose clamp over the fitting that covers the standpipe with a 5/16" nut driver.

Bolt the 3" bolts into the casing adapter on the inside--tightening the casing adapter around the well casing. Snug the bolts up good and tight. You should NOT be able to move the casing adapter at this point.

Wiring of your Sentry I

Better Water Industries, Inc. recommends that a **LICENSED ELECTRICIAN** make the electrical connections. The Sentry I is available in both 115V and 230V to match the voltage of the pump.

When arriving at the job site make sure that you have the right voltage Sentry I with you. Motors are interchangeable between the 115V and 230V and can be ordered separately from BWI. In most instances, a Sentry I system can be installed in less than an hour...providing you have the proper tools.

Note: As a preventive measure against moisture, seal conduit with caulk.

IMPORTANT

MAKE SURE THE ELECTRICITY IS OFF TO THE PUMP BEFORE STARTING YOUR INSTALLATION!

The Electrical Connection

Remove the motor cover on the bottom of the bottom plate for access to the wires. Connect the wires from the BWI *Wire and Vent Kit* to the wires on the motor with the wire nuts and ensure a good connection. Put the conduit fitting in the hole of the motor cover and tighten. Pull the wires out of the well and tie in the wires from BWI's Wire and Vent Kit to the wires on the pump. (Generally, you will find red, black, and yellow wires. Red is normally the starter wire that is tied into the capacitor. Usually you will use the black and yellow wires for a 230V application. Variable Frequency Drives (VFD) application must follow additional installation instructions listed below.)

Connect the well pump wires to the conduit wires on the Sentry I. Again, make sure the connection is secure. Place the wires back in the well casing. Replace the well cap. Make sure the switch is in the "on" position and run water until the pumps runs. The motor gear should turn.

Be sure the drop tube is securely inserted in the drop tube hole on the bottom plate. You may want to drop another chlorine pellet to make sure the pellet is reaching the water.

Applications that use VFD's (constant pressure pumps) **must** trigger the Sentry I with a current switch (part # M 120150). This application **requires** the use of a 115 VAC/60 Hz Sentry I and clean power source with the adjustable current switch clamped around one wire that drives the well pump. After wiring the Sentry I, flow water at a typical usage rate and adjust the current switch to activate or close the switch.

Applications that continuously operate the Sentry I for more than one hour need to install a recycling timer and should install the commercial motor plate. BWI also has an "Accu-Dose" timer for applications where external dose adjustment is desired. (See page PG -12 & PG -13)

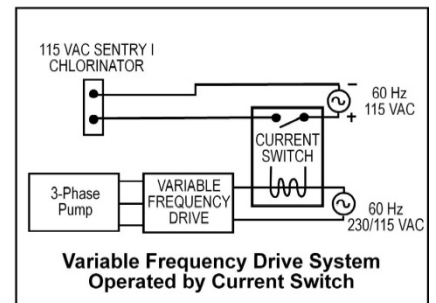
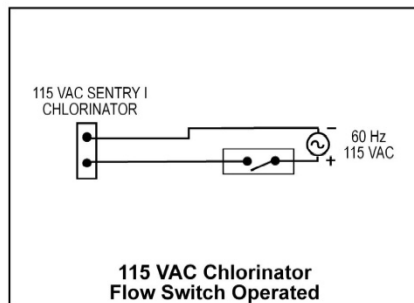
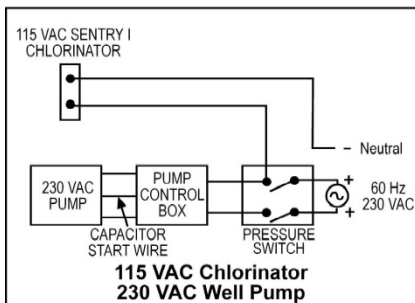
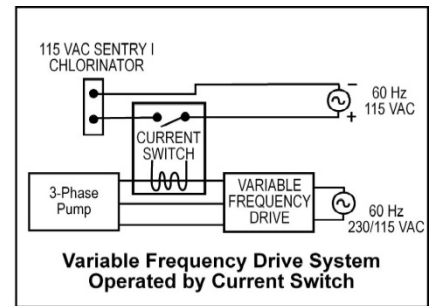
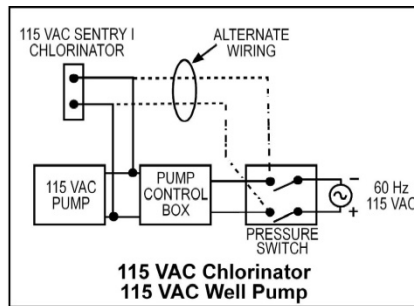
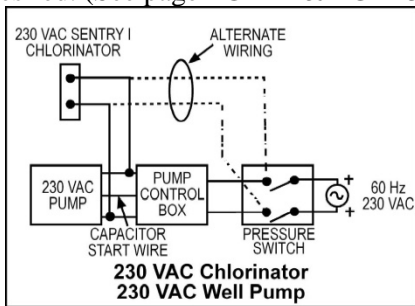

Setting the Sentry I

- As a rule of thumb, just one chlorine pellet (1 gram) will normally treat 30 gallons of water. This "30 gallon figure" is based on "trial and error" field testing over a five year period and is by no means absolute. Each application can vary and the rule of thumb may not apply.
- For a more accurate setting one can figure out the chlorine demand of the water.

Chlorine Demand Calculations

To figure out how many gallons are treated for your specific application you need to know these specifics:

- 0.6 ppm of chlorine is needed to treat 1 ppm of Iron
- 3.0 ppm of chlorine is needed to treat 1 ppm of Sulphur
- 1.2 ppm of chlorine is needed to treat 1 ppm of Manganese
- 1-3 ppm of chlorine is needed to treat 1 ppm of Alga Bacteria

Example: **NOT** all water corresponds to the thirty (30) gallon/per/pellet figure.
Below is an example.

4ppm iron	4x0.6	= 2.4ppm chlorine demand
2ppm sulphur	2x3	= 6.0ppm chlorine demand
3ppm manganese	3x1.2	= 3.6ppm chlorine demand
3ppm iron bacteria algae	3x2	= 6.0ppm chlorine demand
2ppm chlorine (for residual)	2	= 2.0ppm chlorine demand
Total		= 20.0ppm chlorine demand

NOTE: Chlorine demand plus chlorine residual = chlorine dosage

Each 1 gram tablet contains 180ppm available chlorine.

$180 \div \text{chlorine demand} = \text{gallons treated}$

In the above example - $180 \div 20.0 = 9$ gallons/tablet

Determining Pump Production

If the Sentry I Flow Meter is not being used, use the following formula to determine pump rate.

To determine pump rate:

1. Run water until pump starts.
2. Allow pump to run until it stops.
3. Measure water by gallon until the pump starts again.
4. Time pump until it stops.

This is the formula for determining the amount of gallons the pump is producing that determines your pump rate:

$$\frac{\text{_____ gallons}}{\text{(In step 3)}} \div \frac{\text{_____ seconds}}{\text{(In step 4)}} \times 60 = \text{_____ gpm}$$

Note: Pumping time must be measured in seconds-NOT minutes

Sentry I Pellet Gear Settings

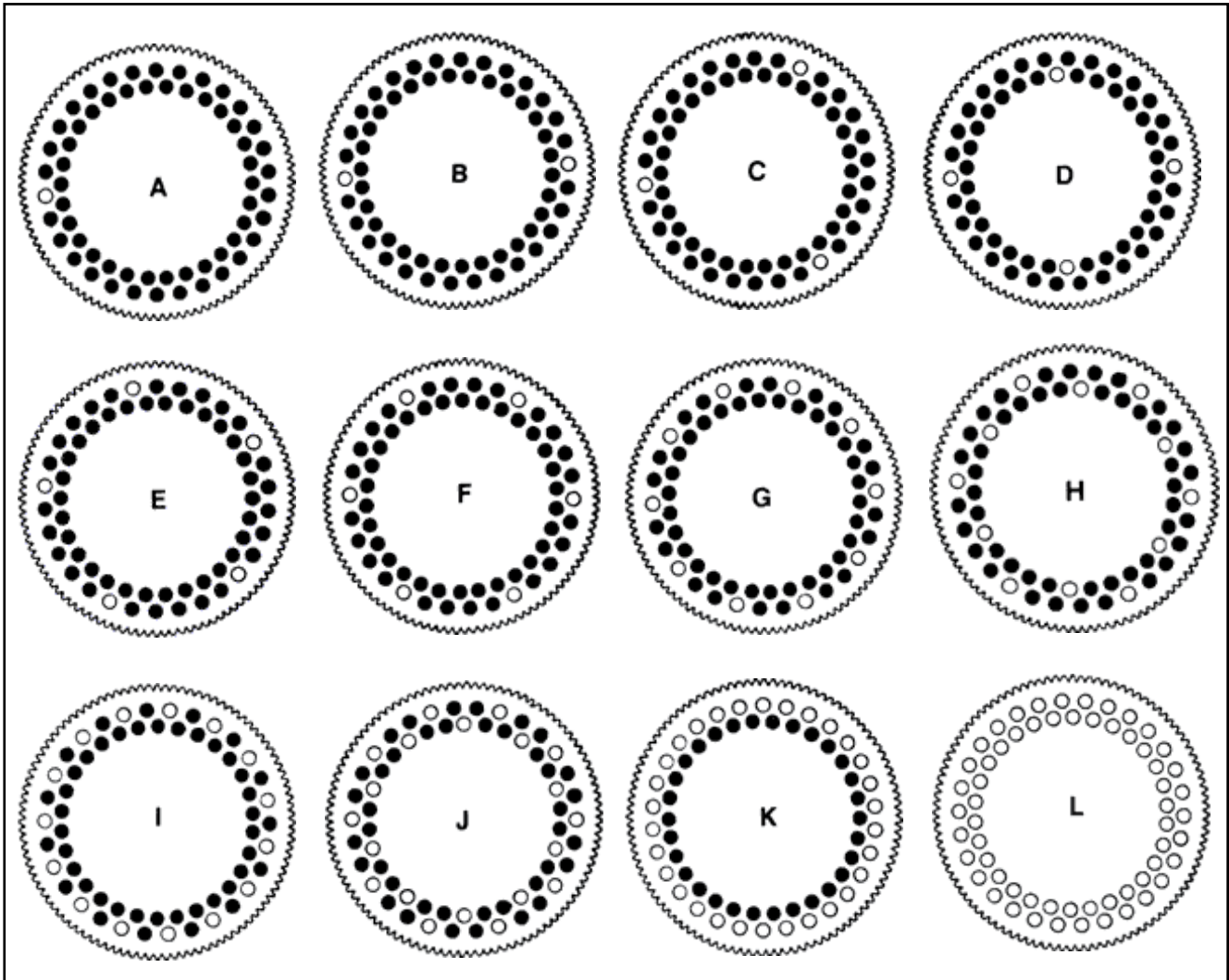

Settings	Plugs Removed	3:1 Gear Ratio
A	1	21 MIN.
B	2	10 MIN. 30 SEC.
C	3	7 MIN.
D	4	5 MIN. 15 SEC.
E	5	4 MIN. 12 SEC.
F	6	3 MIN. 30 SEC.
G	10	2 MIN. 6 SEC.
H	12	1 MIN. 45 SEC.
I	15	1 MIN. 24 SEC.
J	20	1 MIN. 5 SEC.
K	30	42 SEC.
L	60	21 SEC.

	Gallons Per Tablet				
	10	20	30	40	50
3	F	C	B	B	A
5	G	D	C	C	B
7	I	F	E	D	C
8	I	G	F	D	C
9	J	G	F	E	D
10	J	G	F	E	D
12	J	H	G	F	E
15	K	I	G	G	F
20	K	J	H	G	G
25	L	K	I	H	G
35	L	K	J	I	I
50	L	L	K	J	J

Finishing Touches

- 1) Turn on the electricity to the pump and turn the switch on the motor cover to "ON" and make sure the motor drive gear and idler gear move.
- 2) Snap the top plate onto the middle plate making sure the tabs are in place while only using finger tight fastening on the PVC nut & washer.
 - a. If you haven't put the 5 or 10 pound jar of chlorine in yet, turn the middle plate/top plate upside down and screw on the chlorine jar.
 - b. By putting your index fingers on the two tabs on the bottom of the middle plate and lining up the hole for the motor gear, place the assembly back on the bottom plate. Make sure the two fit together without "rocking".
- 3) Finally, put the cover over the entire assembly and tighten it by twisting it.
(Note: The Sentry I label should be on the same side as the drop tube)

Your Sentry I is now ready for operation. Make sure that the switch is in the "ON" position. Before leaving the installation and turning on the Sentry I, make sure the entire installation is watertight and vermin proof. If the installation does not meet these criteria, it will not be approved by some states. BWI recommends purchasing NSF listed and 70% active chlorine from your Sentry I dealer. If your dealer cannot provide you with this product, please call BWI at 507-247-5929 for assistance.

Exploded Parts List

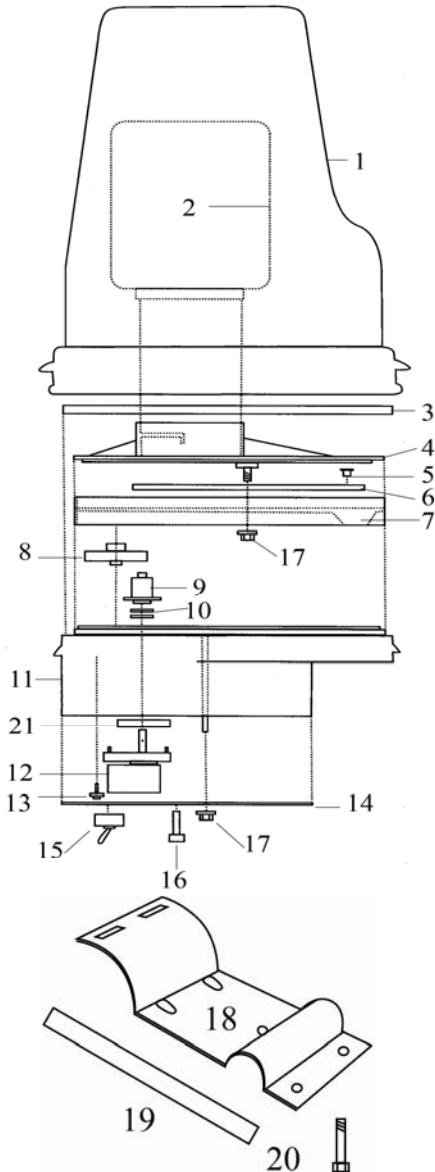

Number	Quantity	Part Number	Description
1	1	S-124701	Cover
2	1	S-124702	Pellet Jar
3	1	S-124703	Cover Seal
4	1	S-124704	Top Plate
5	60	S-124705	Pellet Plugs
6	1	S-124706	Pellet Gear
7	1	S-124707	Middle Plate
8	1	S-124708	Idler Gear
9	1	S-124709	Motor Gear
9	1	S-124709C	Commercial Grade Motor Gear
10	2	S-124710	Motor Gear Seals
11	1	S-124711	Bottom Plate
12	1	S-1247121	110V. Motor Only
12	1	S-1247122	220V. Motor Only
13	3	S-124713	Motor Screws
14	1	S-124714	Motor Cover
15	1	S-124715	Switch
16	1	S-124716	Fuse Holder
17	1	S-124717	PVC Nut & Washer
18	2	S-124718	Casing Adapter
19	2	S-124719	Casing Banding
20	1	S-124720	Bolt Pack Assembly
21	1	S-124721	Motor Shaft Seal

Maintenance & Repair

Removing a motor gear

Removing the motor gear is very simple. This should not be necessary to remove, unless you are changing the motor on the SENTRY I. First, get two (2) screwdrivers and place one on each side of the motor gear. Pry the motor gear up and off. You will notice that there are two motor gear seals still attached to the underside of the motor gear. With your screwdriver, remove the motor gear seals. When reinstalling the motor gear, **install the seals first** by placing it in the space in the bottom plate and ensure you place a small amount of silicone onto the seals. Insert the seal with the cup side down – the flat side up. Make sure it is firmly in place before placing the motor gear over the motor. When placing the motor gear over the motor shaft, make sure that the “T” on the shaft slides down through the corresponding space on the motor gear. Hand tighten so that it slides down all the way.

Changing the motor on the Sentry I

Remove the motor gear. (See above directions). Unscrew the motor cover screw with a screwdriver and remove the motor cover. You will now be able to change motors or replace the fuse. You will see that the motor is held in by three (3) motor screws. Remove those three (3) screws and pull out the motor. When reassembling makes sure that the fuse is in place and that the wire nuts are securely fastened to the electrical connection.

Tips for Installing and Servicing the Sentry I

- 1.) Tipping the pellet jar, top plate and middle plate assembly upside down makes it simple to change the pellet jar.
- 2.) Tightening the 5/16” pvc nut on the underside of the middle plate will insure that the Sentry I gives you trouble free operation. **Careful** – over tightening will bind the pellet gear.
- 3.) Before replacing and tightening the cover, make sure that all plates fit securely together and are ready for operation.
- 4.) Make sure the switch is “**ON**” when leaving your customer. Also, double check to make sure the pellets are dropping unobstructed into the well.
- 5.) Do NOT cut a hole in the pellet jar.
- 6.) The Sentry I cover must always be secured and properly sealed.

Preventive Maintenance

- Lubricate the motor on a annual basis with a three (3) to one (1) oil (Do NOT use WD-40)
- Check pellet gear for chalk build – up and clean if necessary (ensure pellet gear is DRY before inserting the pellet gear back into the unit.)

Notes

- Store chlorine pellets in a cool, dry place out of direct sunlight
- Avoid chlorine pellet fumes
- If for some reason you disconnect the Sentry I for a extended period of time, remove the pellets and place them in storage.
- Rotate stock on chlorine pellets. It is recommended to use tablets within a one year time frame.

Re-circulating Check Valve & Basket Installation

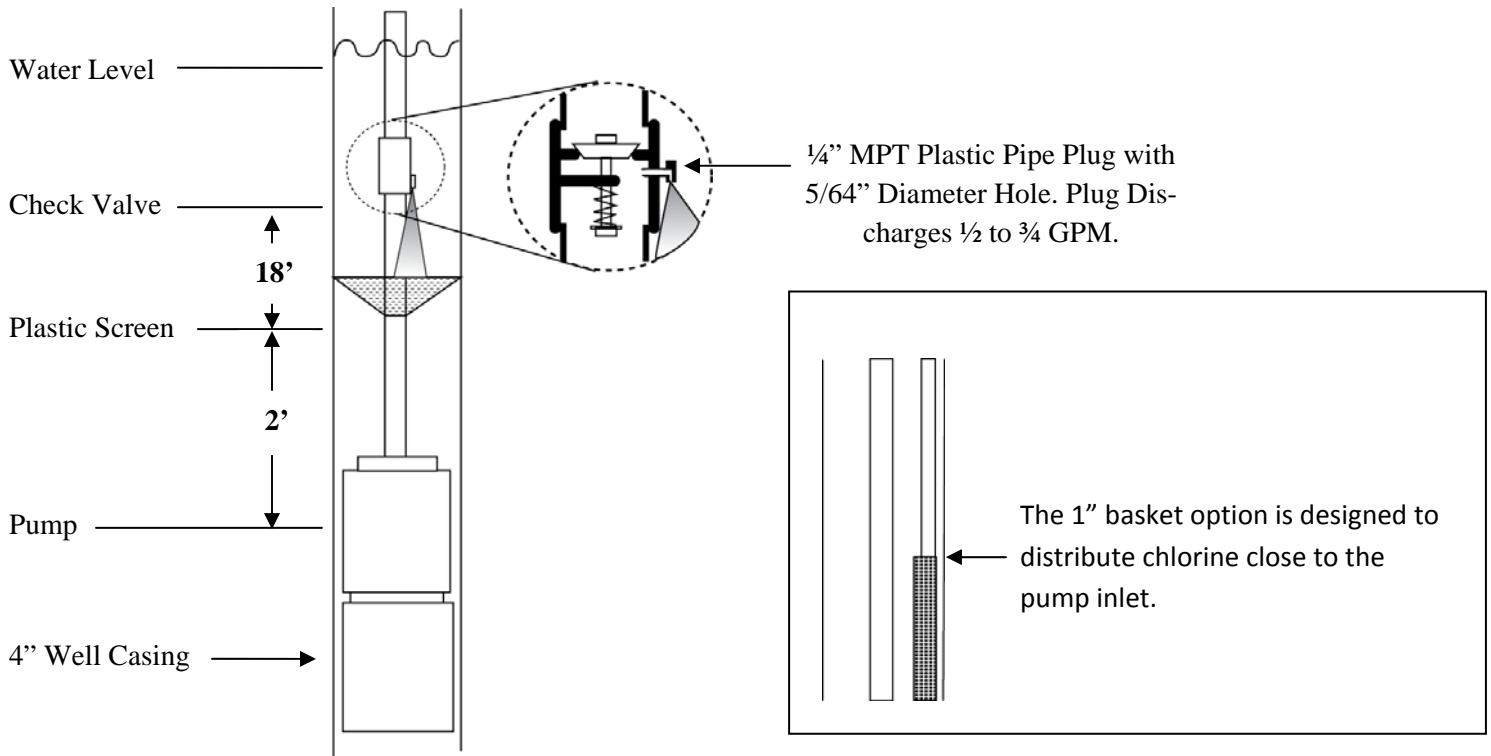

SENTRY I Commercial Chlorinator Specifications

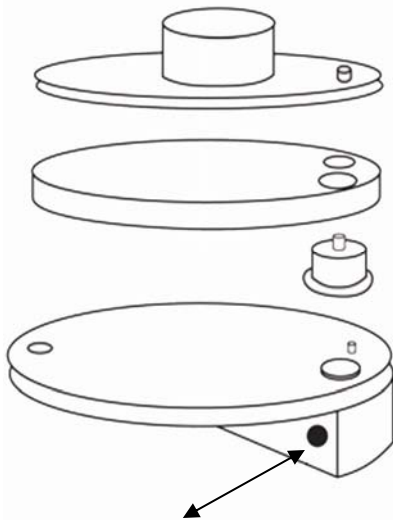

Accu-Dose Timer Adjustment Knob
1% - 100% Run Time

SETTING	PLUGS REMOVED	TIME IN-BETWEEN PELLETT DROPS			
		16 Tooth Motor Gear		10 Tooth Motor Gear Set	
		100%	50%	100%	50%
A	1	4min 40sec	9min 20sec	21min	42min
B	2	2min 20sec	4min 40sec	10min 30sec	21min
C	3	1min 0sec	3min 6sec	7min	14min
D	4	1min 10sec	2min 20sec	5min 15sec	10min 30sec
E	5	56 sec	1min 52sec	4min 12sec	8min 24sec
F	6	47 sec	1min 33sec	3min 30sec	7min
G	10	28 sec	56 sec	2min 6sec	4min 12sec
H	12	23 sec	47 sec	1min 45sec	3min 30sec
I	15	19 sec	37 sec	1min 24sec	2min 48sec
J	20	14 sec	28 sec	1min 5sec	2min 10sec
K	30	9 sec	19 sec	42 sec	1min 24sec
L	60	4.7 sec	9 sec	21 sec	42 sec

Chlorinator Options

The Sentry I Commercial Chlorinator is based on the technology of Better Water Industries, Inc. of Tyler, MN. BWI has the experience with this technology in both residential and commercial applications nationwide.



Sentry I Cover – Part # S 124701
Compatible with our 5 & 10 pound capacity jars.



Commercial Cover - Part# S 124701C
Compatible with the high capacity hopper and reduces internal heat due to sun exposure



5# Jar - Part# CP 22005
10# Jar - Part# CP 22010
Utilized during low to high chlorine consumption (Capacity based on six month usage or less)



25# Jar - Part# CP 22925
Optimized for maximum chlorine capacity (Requires commercial cover)



Motor Gear - Part# S 124709
Idler Gear - Part# S 124708
Designed for low (21 minute) drop rates to high (21 seconds) drop rates



Commercial Motor Gear - Part# S 124709C
Delivers a maximum feed rate up to one tablet Every 4.7 seconds



Accu-Dose Timer - Part# M 120130
Provides external adjustments and cooling during long run cycles



Recycling Timer - Part# M 120141
Provides cost-effective cooling for extended operating cycles



Commercial Motor Plate - Part# S124724
Reduces excess heat and strengthens motor mounting



Current Sensor Switch - Part# M 120150
Operates 110 volt chlorinators with adjustable current sensitivity (used exclusively with 110 volt chlorinators during VFD applications which require “Clean” 60 Hz

SENTRY I	Cover	Jar	Gear	Time	Voltage	Plate	Current Switch
S	1-Regular	1-5#	1-Two (2) Gear set	N-None	1-110V	1-No	1-No
	2-Commercial	2-10#	2-Commercial Gear	A-Accu – Dose * 2	2-220V	2-Yes	2-Yes *3
		3-25# *1		R-Recycling			

1*. Requires Commercial Cover *2. Provides External Adjustments *3. Requires 110V Chlorinator

Water Volume & Contact Time

Diameter of Well	Hole Capacity Gal. per Linear Ft.
1-1 1/4"	0.1
2"	0.2
3"	0.4
4"	0.7
5"	1.1
6"	1.5
8"	2.6
10"	4.1
12"	5.9
14"	8
16"	10.5
18"	13.2
20"	16.3
24"	23.5
30"	36.7
36"	52.9
Diameter of Tank	Gallons per Ft. of Height

Example	
1 ppm	2 ppm
6	6
200	200
80	80
120	120
180	180
15	15
20	
	10
x15	x15
= 300	= 150
- 180	- 180
= 120	= 0

Casing Size
 Depth of Well (ft)
 Static Water Level
 Ft. of Water in casing
 Gallons of water in casing
 Pump flow rate (gpm)

 1ppm Chlorine (20 min contact time)
 2ppm Chlorine (10 min contact time)
 X Pump Flow Rate (gpm)
 = Gallons of water needed for proper contact time
 = Gallons of water in the well
 = Retention tank size needed for proper contact time

Note: The above chart can also be used to determine the dimensions of the retention tank.

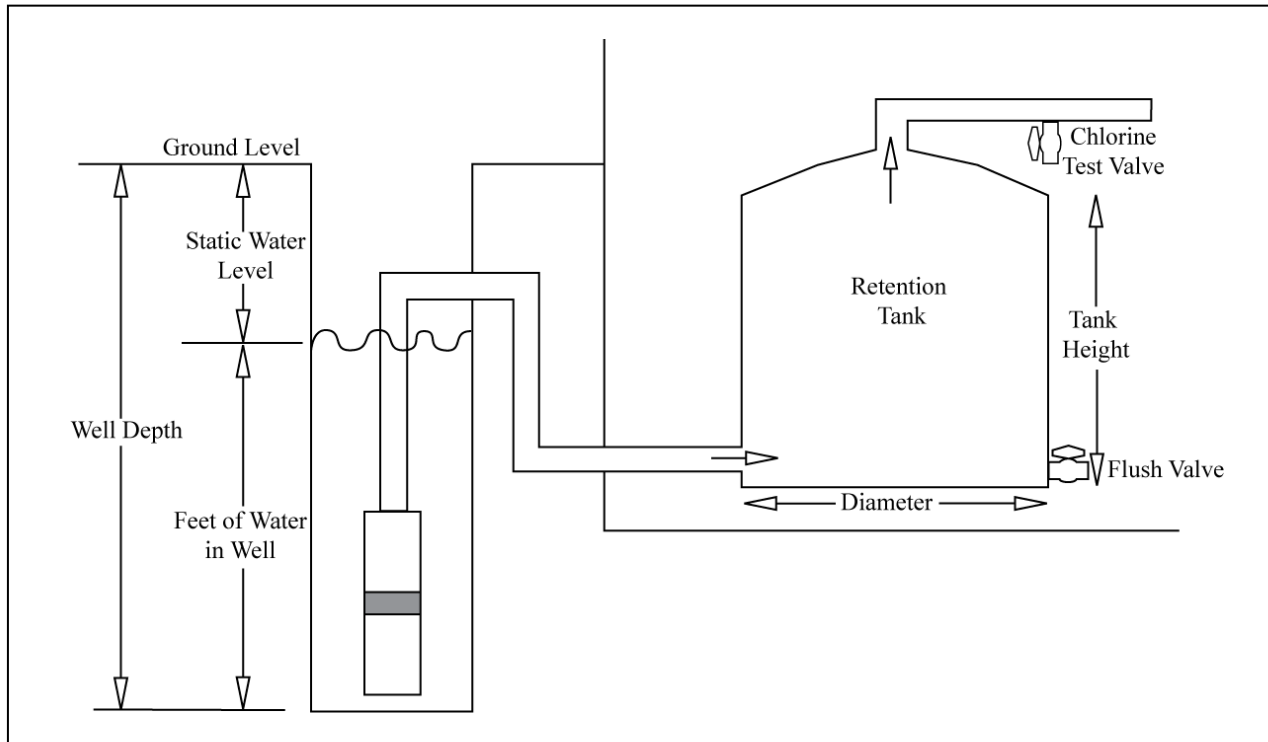

Sentry I on a Storage Tank

- 1) Basket must be mounted by incoming water. (Helping tablets to dissolve)
- 2) Drop Tube (3/4" CPVC) must be below minimum water line.
- 3) Chlorinator should be wired to well pump OR the chlorinator should be wired to the fill float if it is electrical. (When the tanks receive water the chlorinator should be running.)

- The Sentry I can be mounted to the wall or tank.
- The drop tube can have forty-five (45) degree angles in it.

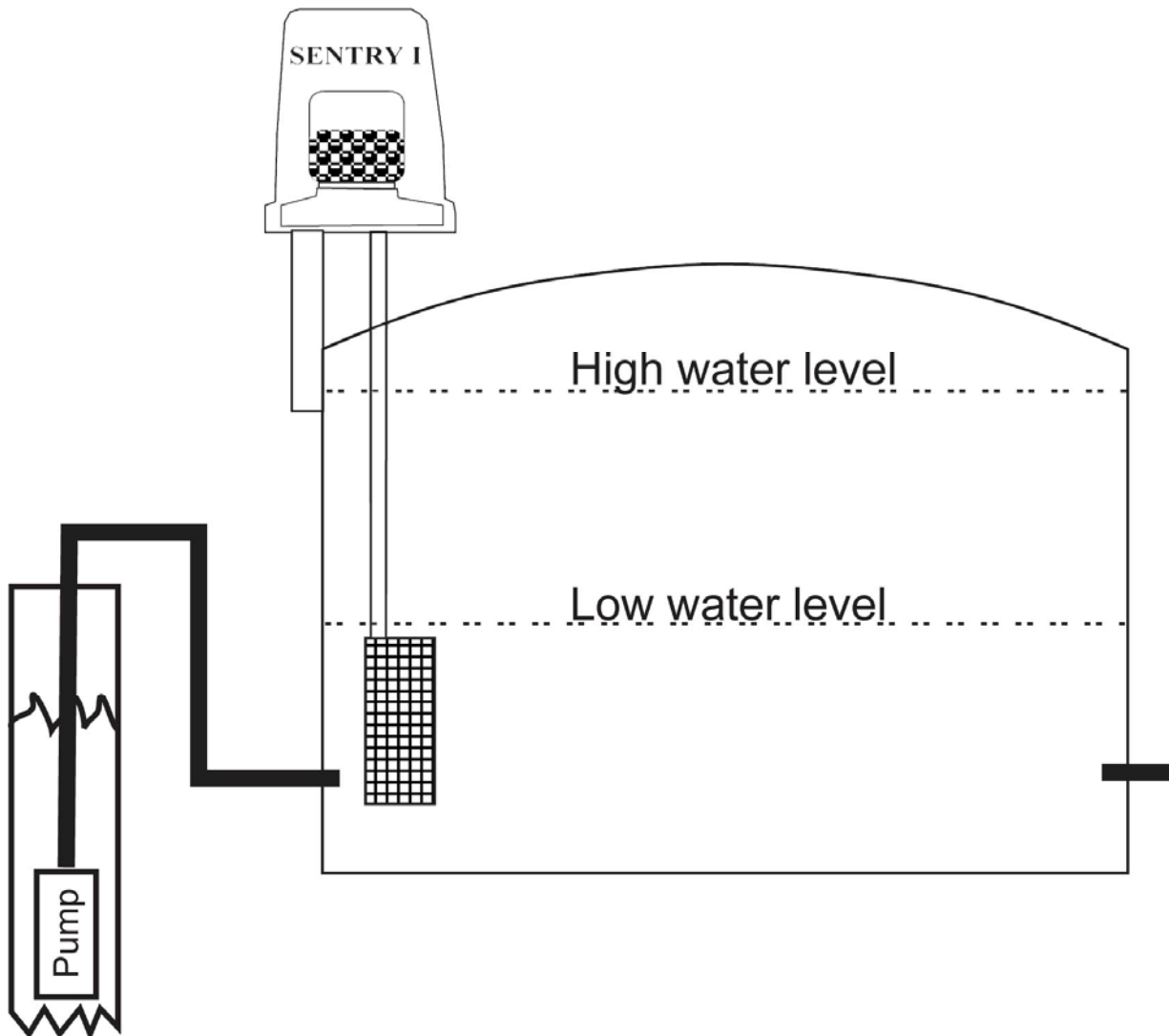

Suggested Filtration

Filters require 15 minute backwash and 10 minute down-rinse

1.5 Cubic ft / 10"x54" require 5gpm backwash and have a residential service flow-rate of 5gpm and a commercial flow-rate of 2.5~3gpm.

3 Cubic feet / 13"x54" require 8gpm backwash and have a residential service flow-rate of 10gpm and a commercial flow-rate of 5gpm

Typically this style filter will filter to ten micron or less and has an expected life of three to five years.

Multi-Media Carbon Filter

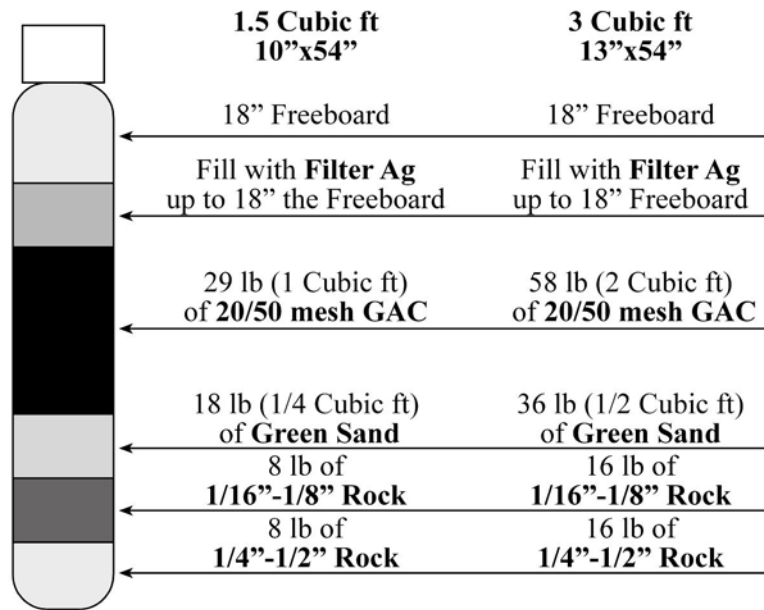

Multi-Media Non-Carbon Filter

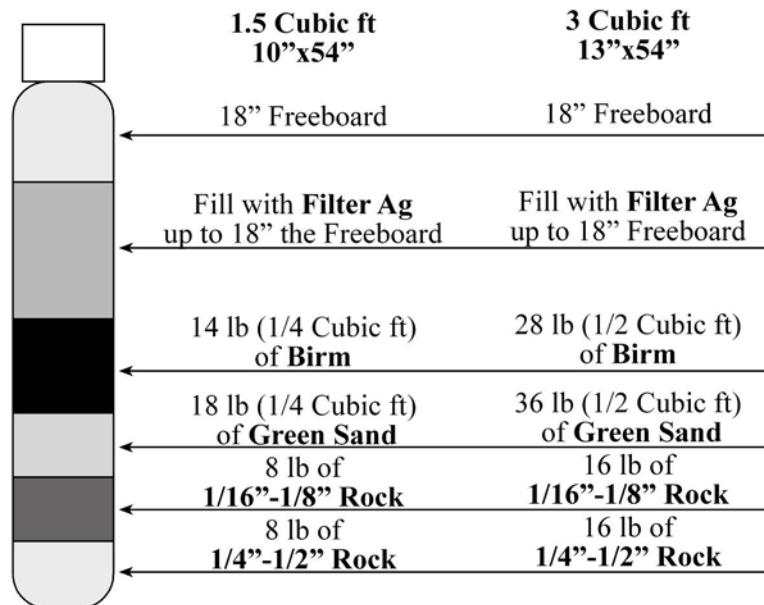

Open – Air Installation

Mandatory Adjustments

- 1) Adjust the Sentry I Chlorinator with the flow rates found in step 12. (Refer to pages PG-8, PG-9 for chlorine dosage and settings.)
- 2) Adjust the Air-Draw Venturi between 20 and 30psi head pressure as shown with inlet pressure gauge when the existing well pump is running. (By adjusting the Air-Draw during the well pump cycle it matches the true flow rate of the well pump.) The Air-Draw tube is the small gray tube located below the Sentry I Chlorinator. This is adjusted by loosening the gray plastic nut and slightly sliding the gray tube up and down. By moving the tube up it restricts the incoming flow rate, increases head pressure, and increases aeration. By moving the tube down it increases the incoming flow rate, decreases head pressure, and reduces aeration.
- 3) Adjust the fill solenoid valve to match the maximum well flow rate. While the existing well pump is running, adjust flow control knob on the solenoid clockwise until there is a slight pressure drop on the inlet pressure gauge.

Optional Adjustments

- 1) On the 10gpm and 25gpm systems, the pressure switch may be adjusted for special applications. Refer to the pressure switch cover for instructions. (On units that do not use a constant pressure valve (CPV) the bladder tank must be charged at two (2) psi less than kick in pressure.)
- 2) Some applications require fine-tuning the CPV to match usage. To do this flow water at a normal constant rate and adjust the bolt on the end of the bell to desired pressure. (Factory setting is 50psi to match the 40/60psi pressure switch. It is recommended to maintain this 10psi differential.)

Installation

- 1) Shut off water to home and remove all pressure to Open-Air System
- 2) Install tank plugs & blow down ball valves
- 3) Lubricate all union o-rings on each union and assembly inlet, outlet and by-pass. (Note: The large rubber washer is used with the brass CPV if equipped)
- 4) Plumb inlet water to open air (If debris is present, install a sand separator prior to the Open Air's Inlet.)
- 5) Connect 3/8" pressure switch line to the two quick connectors (located on the J-box and on the ball valve assembly)
- 6) Install bladder tank to outlet assembly (Over tightening may cause a severe leak)
- 7) Place Sentry I Chlorinator on plastic stand pipe and secure the 3/4" CPVC drop tube to the bottom of the chlorinator
- 8) Plumb additional treatment equipment after Open-Air System such as a multi-media filter
- 9) Plumb 1-1/2" overflow to adequate drain or secure a five (5) gallon pail with safety float to shut off the existing well pump or water supply
- 10) Plumb 2" vent tube in a naturally rising configuration from the Open-Air System (check local building codes for proper installation) Air Stripping package utilizes a minimum of 1-1/4" powered exhaust.
- 11) Pressurize the water system up to the Open-Air
- 12) Flow rate well with Sentry Flow Meter (Refer to Sentry Flow Meter literature on Page-22)
- 13) Energize system and perform mandatory adjustments listed above (Dedicated 20amp 110volt service or 20 amp 220 volt service is required)

Note: If the pump makes a "growling" noise unplug unit immediately and draw water into pump by applying a light vacuum to an outgoing water line such as the 3/8" pressure switch line.

- 14) Fill Sentry I Chlorinator with appropriate chlorinating tablets (One (1) gram BWI Chlorinating tablets are recommended.)
- 15) Check for leaks
- 16) Test chlorine residual two (2) days after installation. Most target residuals are between 1.5 – 2.5 ppm.

Open – Air Installation Summary

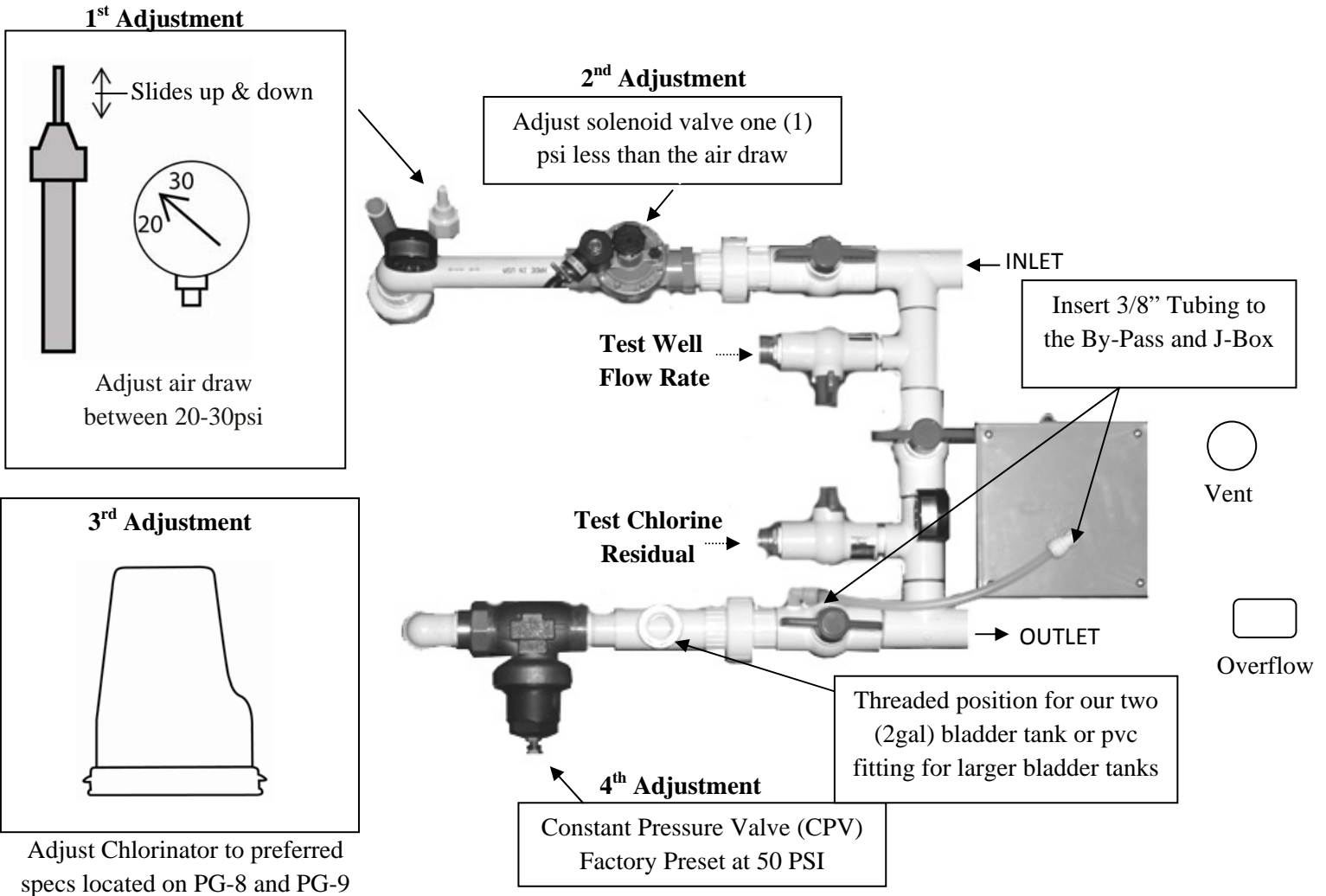

Conventional Layout

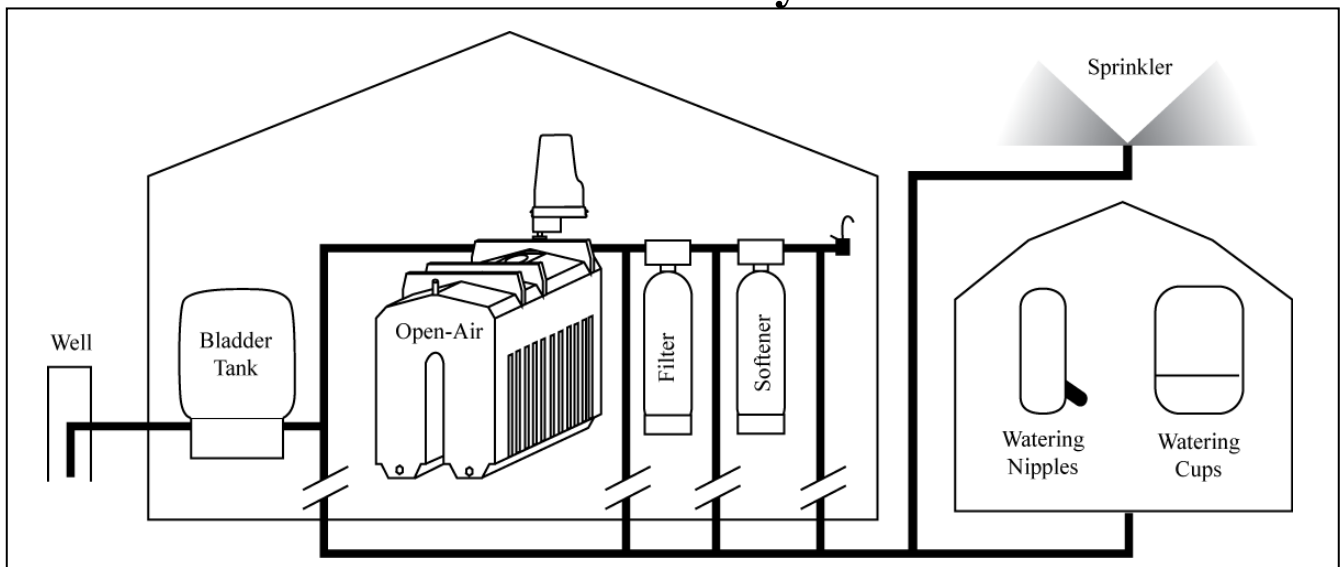

Open – Air Wiring Diagram

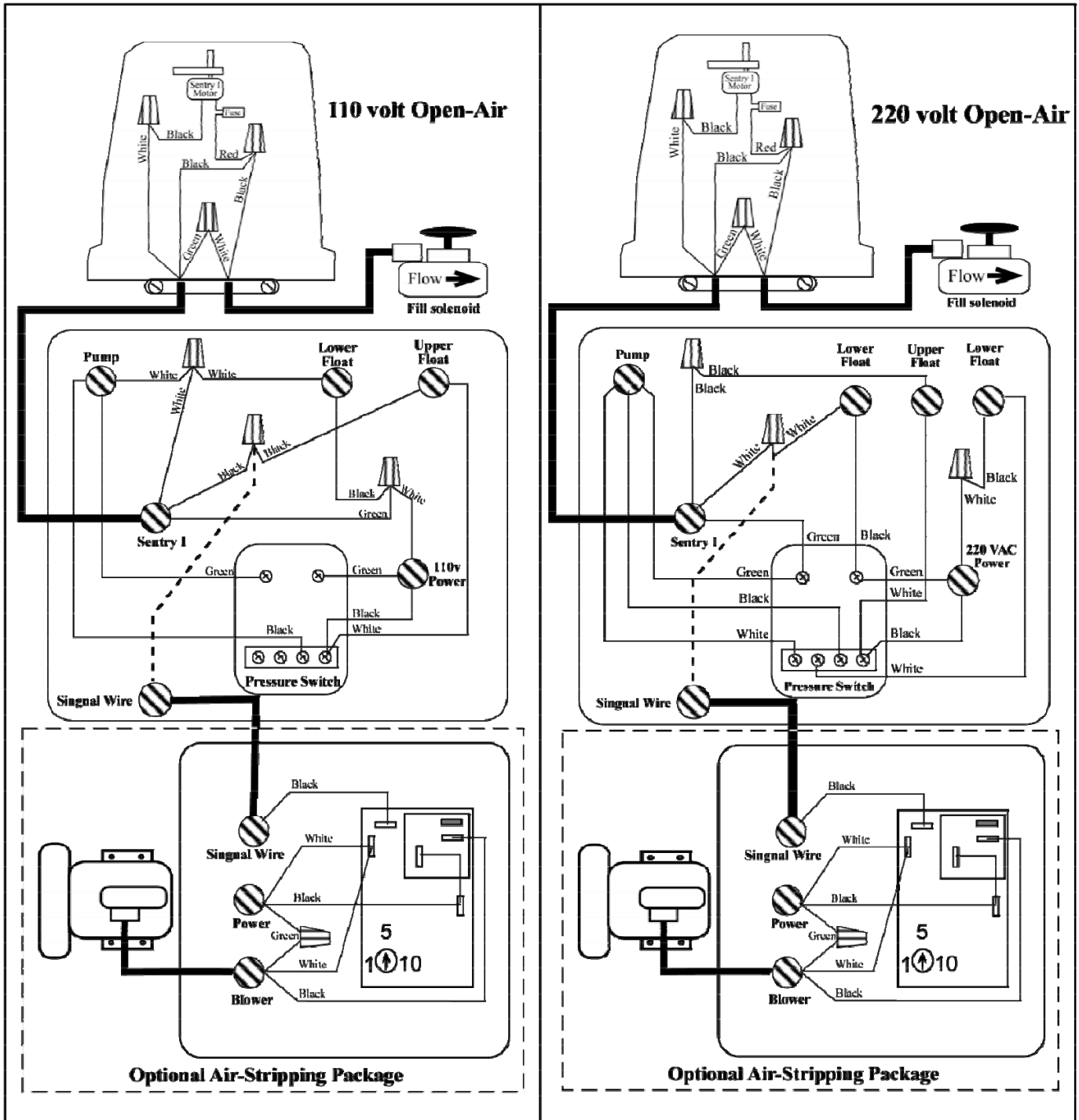

Open – Air Specifications

Specifications			
Continuous Flow	10 gpm	18 gpm	25 gpm
Max Flow	14 gpm	22 gpm	28 gpm
Capacity	130 gal	130 gal	300 gal
Voltage	115 VAC	115 VAC	230 VAC
Operating Current	10 amp	10 amp	6.8 amp
Max Current	12 amp	12 amp	8 amp
Power	1/2hp	1/2 hp	3/4 hp
Frequency	60 Hz	60 Hz	60 Hz
Dimensions (LxWxH)	43"x27"x59"	43"x27"x59"	48"x32"x76"
Clearance Needed	45"x27"x65"	45"x27"x65"	50"x33"x82"
AB Weight	170 lb	170 lb	215 lb
Gas Reduction	200 lb	205 lb	245 lb
Radon	205 lb	210 lb	250 lb
Tank Height (T)	45"	45"	61"

SENTRY I	
Pellet Feed Rate (Max)	8 Pellets per minute
Pellet Feed Rate (MIN)	1 Pellet per 21 minutes
Pellet Storage	5 or 10 lbs container

SENTRY I (Air Stripper)	
Max Vacuum	35" H2O
Max Air Flow	43 cfm
Voltage	115 VAC
Operating Current	3.8 amp
Power	1/3 hp
Frequency	60 Hz

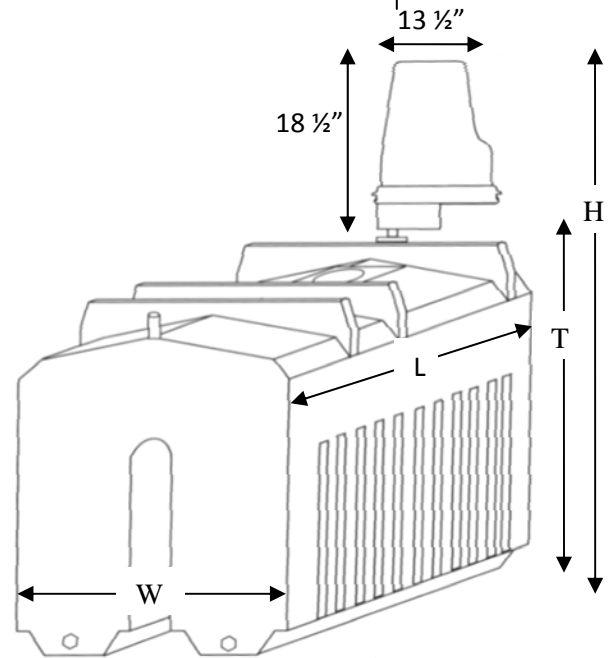

Scheduled Maintenance

- 1) Two (2) days after installation, the chlorine residual needs to be tested between 0.5 and 3.5ppm. (BWI recommends 1.5-2.5ppm residual) Test water from a down-stream test port; do not check residual from water dipped out of the tank. If the Sentry I Chlorinator needs adjustment, repeat this step every two (2) days until desired residual is achieved.
- 2) Check chlorine tablet level inside the Sentry I chlorinator every month until a refill schedule is determined. A typical house-hold consumes 8-15 lbs per year.
- 3) Chlorine residual should be tested at a minimum of every six (6) months or anytime any of the treatment equipment is serviced. If the Sentry I Chlorinator needs adjustment, repeat step one (1).
- 4) Proper float operations should be checked every six (6) months. Flow water and visually confirm proper float operation. (The unit should fill when the upper electronic float, not the mechanical ball float, drops and opens the solenoid.)
- 5) While checking floats, ensure the bottom of drop-tube is remaining below the water level at all times.
- 6) Proper pressure operation should be check every year. Flow water until pump kicks in and record pressure. Then shut water off and check kick-out pressure and record. Factory setting is 40/60psi.

Note: Some water applications may require increased maintenance checks

Note 2: BWI recommends professional maintenance contracts with most treatment applications that require the Sentry I Open-Air System.

Open-Air Parts List

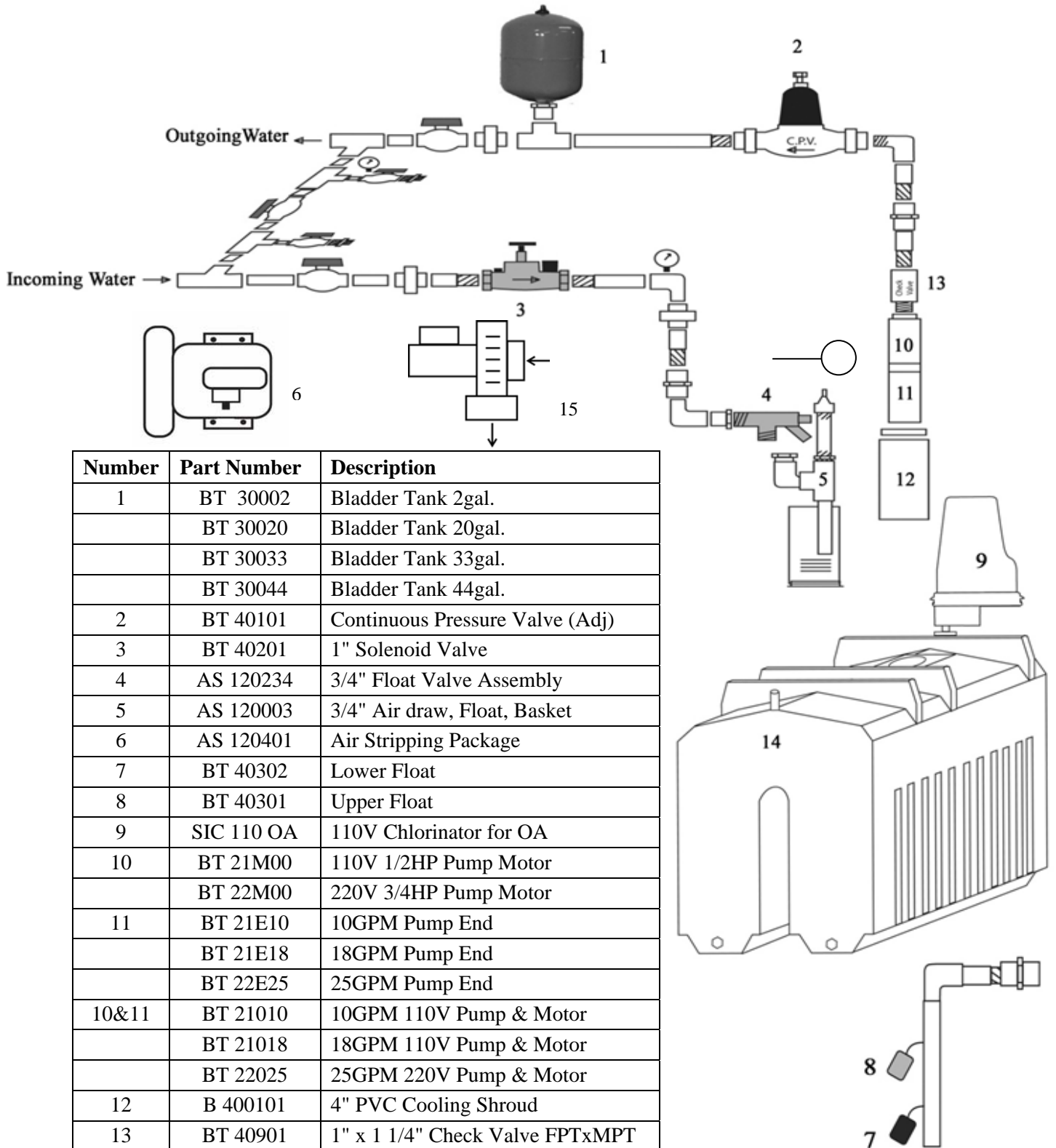

Number	Part Number	Description
1	BT 30002	Bladder Tank 2gal.
	BT 30020	Bladder Tank 20gal.
	BT 30033	Bladder Tank 33gal.
	BT 30044	Bladder Tank 44gal.
2	BT 40101	Continuous Pressure Valve (Adj)
3	BT 40201	1" Solenoid Valve
4	AS 120234	3/4" Float Valve Assembly
5	AS 120003	3/4" Air draw, Float, Basket
6	AS 120401	Air Stripping Package
7	BT 40302	Lower Float
8	BT 40301	Upper Float
9	SIC 110 OA	110V Chlorinator for OA
10	BT 21M00	110V 1/2HP Pump Motor
	BT 22M00	220V 3/4HP Pump Motor
11	BT 21E10	10GPM Pump End
	BT 21E18	18GPM Pump End
	BT 22E25	25GPM Pump End
10&11	BT 21010	10GPM 110V Pump & Motor
	BT 21018	18GPM 110V Pump & Motor
	BT 22025	25GPM 220V Pump & Motor
12	B 400101	4" PVC Cooling Shroud
13	BT 40901	1" x 1 1/4" Check Valve FPTxMPT
14	BT 50010	Tank 130 Gallon
	BT 50525	Tank 300 Gallon
15	AS 120601	Exhaust Fan Kit

Sentry Flow Meter

- 1.) Blow off debris in line before attaching Sentry Flow Meter
- 2.) Attach the flow meter to a hydrant or hose bib by the pressure tank.
- 3.) Open the hydrant or hose bib to maximum flow. Partially close the ball valve to a slow water run until the pump starts. Read the pressure gauge. _____ **psi** (kick-in pressure)
- 4.) Open the ball valve. Read the flow meter _____ **gpm** (No-Head Pressure)
- 5.) Close the ball valve. Allow pump to run until it turns off.

Read the pressure gauge. _____ **Psi** (kick-out pressure)
- 6.) With the pump running adjust the ball valve until the pressure gauge reads thirty (30psi.) Allow the water to run at least one (1) minute at this pressure. Read the flow meter. Use this reading in conjunction with the Sentry I sizing chart located on PG-8. It also tells you how much water is available for other appliances and equipment.
gpm _____
- 7.) With the pump running adjust the ball valve until the pressure gauge shows forty (40psi.) Allow the water to run at least one (1) minute at that pressure. Read the flow meter. The difference in the thirty (30psi) reading and the forty (40psi) reading determines if the pump is in good condition.

_____ **gpm**

The gallons per minute should not vary more than twenty-five (25) percent. _____

The Sentry Flow Meter provides accurate flow rates of pumps from zero (0) to one-hundred (100) psi, at flow rates anywhere from four (4) to twenty-eight (28) gpm.

Note: Damage to the flow meter gauge will occur if exposed to freezing temperatures for extended periods of time.

Additional Value

The Sentry Flow Meter is compatible and a great tool to use when providing routine maintenance on the Open-Air units. The installation kit has two (2) built in test ports that are well-suited with the Sentry Flow Meter. The 1st test port is located on the solenoid side of the unit. This port will allow you to test the well flow rate. The 2nd test port is for testing chlorine residual coming from the Open-Air unit itself as well as testing the Open-Air flow rate.

The unique design was engineered after years of trying to diagnose water pressure problems in various applications. By adjusting the versatile ball-valve, the flow meter can tell you the condition of the pressure tank, pressure switch, pump and if there are any restrictions within the water line. This will help to determine if the problem is in the water pump system or in the water distribution system. Other common usages are detecting scaling in pipes in city water applications by showing low flow rates and severe pressure drops.

Trouble Tree

Attention: All diagnostics should be preformed within normal operated water levels. If electrical work is needed please consult a certified electrician.

SYMPTOM	POSSIBLE CAUSES	SOLUTION
Pump will not Pump Water	Air-Locked Pump (New Installation or after emptying unit)	Remove the 3/8" flex tube from the pressure switch and circulate water. (If water doesn't circulate apply suction to the 3/8" tube to prime the pump.)
Pump Loses Pressure Over Night	Air-Locked Pump (Drawing the unit down too far)	The incoming water should be greater or equal to the outgoing water. Use flow restrictor on outgoing water if needed and adjust lower float up two inches.
Pump Loses Pressure During Low-Volume Usage (showers)	Air-Locked Pump (Gasses in Water such as Methane Applications)	A standard 40/60 pressure unit is needed for this application. To convert an Aqua Booster to 40/60, remove the constant pressure valve, remove the two gallon bladder tank, and add adequate sized bladder tank for unit. (10gpm use 20gal, 18gpm use 33gal, and 25gpm use 44gal)
Low Water Pressure (Flow Test System With Flow Meter)	Coated / Fouled Impellers	Clean wet end of pump with solvent that dissolves unwanted material.
	Large Internal Leak	Shutoff out-going water. System should build up and hold pressure. If not check for internal leak or faulty check valve.
	Improperly Adjusted Constant Pressure Valve	Adjust constant pressure valve by flowing low to a normal amount of water. Adjust bolt on black bell housing to around 55psi on 40/60 applications. (These instructions are rule-of-thumb)
	Over Pumping	Verify flow rate of system and compare with demand.
	Faulty Wet-End	Replace wet end of pump (Units before 2004 may need unit specific wet-end)
Pump Motor not Running / Spinning	No Power to Unit	Check outlet for appropriate power source
	Faulty Pressure Switch	Remove the gray J-box cover and inspect the pressure switch, switch contacts, and voltage at switch. (If contacts are burnt, check for dedicated adequate power source, bladder tank, and constant pressure valve if equipped.)
	Faulty / Locked Wet End	Inspect pump end, remove screen, and manually turn the motor shaft. (should spin easily)
	Faulty Lower Float	Ohm test the low float for proper operations. The lower float is normally open in the downward position.
	Faulty Pump Motor	Replace Pump Motor*

*When removing the pump place a vice grip on the inside of the tank on the PVC union avoiding any crimping of wiring and then remove the constant pressure valve union and begin to unthread the PVC nipple on the top side of the tank.

SYMPTOM	POSSIBLE CAUSES	SOLUTION
Rapid Pump Cycling (faster than one second)	Faulty Pressure Tank	Check pressure in bladder tank. (factory setting for the 2 gal tank is 28 psi and 38 psi for larger ones)
	No Pulse Plug in Pressure Switch	ONLY used in applications with bladder tanks larger than 2 gallons. Pulse plugs are located below the 1/4" NPT thread of the pressure switch.
Short Pump Cycling	Faulty Pressure Tank	Check pressure in bladder tank. (2 gal tanks 28 psi, larger ones 38 psi factory)
	Faulty Constant Pressure Valve	Option #1: Clean, service, or replace valve. (Red and white plastic Cycle Stop valves should be replaced with the brass constant pressure valve.)
		Option #2: Remove valve and replace 2 gallon bladder tank with adequate sized bladder tank for system. (Systems prior to 2004 use a black "T" style constant pressure valve. Remove the spring and plastic plunger under the 1" pressure gauge plug. Then replace the 2 gallon bladder tank with adequate sized bladder tank for system.)(10gpm use 20gal, 18gpm use 33gal, and 25gpm use 44gal)
Faulty Check Valve or Internal Leak	Shut off water to house, let the system build up pressure and shut off. If the unit losses pressure there is an internal leak or bad check valve.	
Unit Not Filling	Bad Wire Connection	Check connections and voltages (Refer to Voltage Check cut sheet)
	Faulty Solenoid Valve	Replace solenoid only
		Replace entire solenoid valve
Faulty Upper Float	Ohm test the upper float (Normally closed in down position) (If chlorinator is running when upper float is down, the float is most likely GOOD)	
Unit Filling Slow (Inlet pressure gauge below 5psi)	Solenoid Valve Direction	On new installs verify flow direction of solenoid valve
	Low Incoming Water Flow / Pressure	Check incoming water flow / pressure
		Check pre-filter if installed
Unit Filling Slow (Inlet Pressure gauge above 5psi)	Improperly Adjusted Safety Float Valve	On new installs verify proper safety float adjustment. (Refer to installation instruction) (Electronic floats are factory set and should not need to be adjusted.)
	Plugged Air-Draw	Readjust Air-Draw tube (See installation instructions and start by tapping down the Air-Draw tube slightly)
		If the Air-Draw is internally coated with debris, clean by dissolving debris with a solvent.

SYMPTOM	POSSIBLE CAUSES	SOLUTION
Unit is Over Flowing	Debris in Solenoid Valve	Clean Valve (In high turbidity water a spin-down filter or sand separator should be installed ahead of the solenoid.)
	Improperly Adjusted Float Settings	On new installs verify proper safety float adjustment. (Refer to installation instruction) (Electronic float are factory set and should not need to be adjusted.)
	Faulty Upper Float	Ohm test the upper float (contact is open when float is up) (If chlorinator is running when upper float is in up position, the float is most likely BAD)

Sentry I Chlorinator on Open-Air System or Holding Tank

SYMPTOM	POSSIBLE CAUSES	SOLUTION
1) Broken Motor Gear 2) Intense Chlorine Smell Under Chlorinator Cover 3) Heavy Corrosion or Rust on Motor 4) Top and Middle Plate Separation 5) Moisture in Pellets 6) Heavy Chalk on Pellet Gear	Drop Tube not Always in Water (Open-Air or Storage Tanks)	Drop-tube should be 24" long or always submerged in water
		The incoming water should be greater or equal to the outgoing water. Use flow restrictor on outgoing water if needed.
	High Static Water Level (20' or less)	Extend new Drop Tube with point in water 1' and NO holes drilled in tube
	Faulty Cover Seal	Replace white foam cover seal.
	Hole in Pellet Jar	Replace jar
	Hole in Chlorinator Cover	Replace cover
	Conduit not Sealed	Caulk one end of conduit
	Chlorinator Cover Removed	Install cover
Motor not Running	No Power to Motor	Check and/or replace fuse(s)
		Check for power on both sides of switch
		Check electrical connections
		Replace upper float (Open-Air applications)
Armature not Turning Unit Not Full of Water	Loosen and lubricate armature with 3 in 1 oil Fill Tank With Water	
Chlorinator Will NOT Shut OFF (line pressure on inlet gauge)	Mechanical Float Mis Adjusted	Adjust mechanical float up so it doesn't shut off water during normal fill cycle. (Make sure it does shut off water in the event of an overflow.)

NOTE: For proper sanitation and oxidation the pH of the water must be between 6.8 and 7.6. Failure to correct pH problems may result in unsatisfactory results and possible equipment damage.

A filter is vital to the success of desired water quality. Once the Sentry I or the Sentry I Open-Air System has oxidized the contaminants in the water, they must be removed prior to entering the residence or building's water system. Small, inline sediment filters will not work for these applications.

After years of field-testing results, BWI recommends the two Multi-bed filters as described on pages PG-16 of the BWI dealer manual. The use of carbon is at the discretion of the homeowner. That decision to use the Multi-bed Filter with or without carbon depends on if the homeowner wants chlorine for continual disinfection or would prefer no chlorine residual at all. Variations from these suggested filters may affect the water quality.

Test Survey

I. Well:

1. Well Age _____ yrs
2. Well Depth _____ ft
- A. Static Water Level _____ ft
- B. Pump Depth _____ ft
3. Casing Size _____
- A. Type: Steel _____ Plastic _____ Cement _____

II. Pump:

1. Age _____ yrs
2. Hp _____ Voltage _____ Phase _____
3. Type: Jet _____ Submersible _____ Stroke _____ VFD _____

III. Flow Rate:

1. GPM _____ GPD _____

IV. Pressure Tank:

1. Size: _____ X _____ Gallon _____
2. Type: Bladder _____ Non-bladder _____

V. Incoming Lines:

1. Size: _____ inches.
2. Type: Copper _____ Galvanized _____ Plastic _____

VI. Lavatory:

1. Hard Water _____ Soft Water _____

VII.

1. Hardness _____ gpg
2. Iron (rust) _____ ppm Bacterial _____ Red Water _____ Clear Water _____
3. pH _____
4. TDS _____ ppm
5. Tannins _____ ppm
6. Methane Yes _____ No _____
7. Radon _____ Yes _____ No _____
8. Nitrates _____ ppm
9. Sulfates _____ ppm
10. Hydrogen Sulfide: Yes _____ No _____ ppm _____
11. Other _____

VIII. Type of Equipment Present:

1. _____ 2. _____
3. _____ 4. _____

Customer Wants/Comments: _____

Future Appointment: Date _____ Time _____

System Notes

Warranty

WE THE PEOPLE of Better Water Industries, in order to truly provide you, our CUSTOMER, with the highest quality of water, both today and tomorrow, do provide you with these LIMITED WARRANTY'S.

Sentry I Open – Air System

Article I: Better Water Industries, Inc. 209 North Tyler St. Tyler, MN 56178 ("BWI"), warrants and promises that its Sentry I Open-Air System is free of defects in materials and workmanship at the time the Sentry I Open-Air System leaves the factory.

Article II: If a defect develops in any of the Sentry I Open-Air System, except for the chlorinator, for up to twelve (12) months from ship date, Better Water Industries, Inc. will, at its option, replace, or rebuild said defective part according to Article V.

Article III: If a defect develops in chlorinator electronics for up to twenty-four (24) months from ship date, Better Water Industries, Inc. will, at its option, replace, or rebuild said defective part according to Article V.

Article IV: If a defect develops in chlorinator housing or any plastics of the chlorinator for up to sixty (60) months from ship date, Better Water Industries, Inc. will, at its option, replace, or rebuild said defective part according to Article V.

Article V:

Section One: Return the defective part to BWI Inc. postage prepaid.

Section Two: Enclose a return tag with a written description of the defect.

Section Three: Also enclose a written statement assuring BWI Inc. that the product was properly installed, not misused or abused.

Section Four: Replacements or Credit will be issued after BWI Inc. inspects the unit and concurs on said defect.

Article VI: BWI Inc. warrants all replacement parts for ninety (90) days from date of shipment.

Article VII: There are no other warranties, whether expressed or implied, which extend beyond this written warranty.

Sentry I Dry – Pellet Chlorinator

Article I: Better Water Industries, Inc. 209 North Tyler Street, Tyler, Minnesota 56178, warrants and promises that it's Sentry I Chlorinator is free of defects in materials and workmanship at the time the Sentry I leaves the factory.

Article II: If a defect develops in any of the electrical components for up to twenty-four (24) months from the shipment date, Better Water Industries, Inc. will, at its option, replace, repair, or rebuild the motor according to the Article IV.

Article III: If a defect develops in the housing or any other parts of the Sentry I for up to sixty (60) months from shipment date, Better Water Industries, Inc. will, at its option replace, or rebuild the unit according to Article IV.

Article IV:

Section One: Return the defective part to BWI Inc. postage prepaid

Section Two: Enclose the return tag with a written description of the defect.

Section Three: Also enclose a written statement assuring BWI Inc. that the products were properly installed, not misused or abused.

Section Four: Replacement or Credit will be issued after BWI Inc. inspects the unit and concurs on the said defect.

Article V: BWI Inc. warrants all replacement parts for ninety (90) days from date of shipment.

Sentry I Commercial Dry – Pellet Chlorinator

Article I: Better Water Industries, Inc. 209 North Tyler Street, Tyler, Minnesota 56178, warrants and promises that it's Sentry I Commercial Chlorinator is free of defects in materials and workmanship at the time the Sentry I leaves the factory.

Article II: If a defect develops in any of the electrical components for up to twelve (12) months from the shipment date, Better Water Industries, Inc. will, at its option, replace, repair, or rebuild subject to the following.

Article III:

Section One: Return the defective part to BWI Inc. postage prepaid.

Section Two: Enclose a return tag with a written description of the defect

Section Three: Also enclose a written statement assuring BWI Inc. that the product was properly installed, not misused or abused.

Section Four: Replacement or Credit will be issued after BWI Inc. inspects the unit and concurs with said defect.

Article IV: BWI Inc. warrants all replacement parts for ninety (90) days from date of shipment.

Professional installation is required for warranty.

There are no other warranties, whether expressed or implied, which extend beyond this written warranty.

IN WITNESS WHEREOF, I have hereunto subscribed my name:

L. Burckhardt, President BWI Inc.

T. Burckhardt, Vice-President BWI Inc.

Copyrighted BWI Inc. 2008

BWI – We take pride in protecting your water.